

English version

**Eurocode 1: Actions on structures - Part 1-1: General actions -
Densities, self-weight, imposed loads for buildings**

Eurocode 1: Actions sur les structures - Partie 1-1: Actions
générales - Poids volumiques, poids propres, charges
d'exploitation bâtiments

Eurocode 1: Einwirkungen auf Tragwerke - Teil 1-1:
Wichten, Eigengewicht und Nutzlasten im Hochbau

This European Standard was approved by CEN on 30 November 2001.

CEN members are bound to comply with the CEN/CENELEC Internal Regulations which stipulate the conditions for giving this European Standard the status of a national standard without any alteration. Up-to-date lists and bibliographical references concerning such national standards may be obtained on application to the Management Centre or to any CEN member.

This European Standard exists in three official versions (English, French, German). A version in any other language made by translation under the responsibility of a CEN member into its own language and notified to the Management Centre has the same status as the official versions.

CEN members are the national standards bodies of Austria, Belgium, Czech Republic, Denmark, Finland, France, Germany, Greece, Iceland, Ireland, Italy, Luxembourg, Malta, Netherlands, Norway, Portugal, Spain, Sweden, Switzerland and United Kingdom.



EUROPEAN COMMITTEE FOR STANDARDIZATION
COMITÉ EUROPÉEN DE NORMALISATION
EUROPÄISCHES KOMITEE FÜR NORMUNG

Management Centre: rue de Stassart, 36 B-1050 Brussels

CONTENTS

	Page
FOREWORD.....	4
BACKGROUND OF THE EUROCODE PROGRAMME	4
STATUS AND FIELD OF APPLICATION OF EUROCODES	5
NATIONAL STANDARDS IMPLEMENTING EUROCODES.....	6
LINKS BETWEEN EUROCODES AND HARMONISED TECHNICAL SPECIFICATIONS (ENs AND ETAs) FOR PRODUCTS	6
ADDITIONAL INFORMATION SPECIFIC FOR EN 1991-1-1	6
NATIONAL ANNEX FOR EN 1991-1-1	7
SECTION 1 GENERAL	8
1.1 SCOPE	8
1.2 NORMATIVE REFERENCES	9
1.3 DISTINCTION BETWEEN PRINCIPLES AND APPLICATION RULES.....	9
1.4 TERMS AND DEFINITIONS.....	10
1.5 SYMBOLS	11
SECTION 2 CLASSIFICATION OF ACTIONS	12
2.1 SELF-WEIGHT	12
2.2 IMPOSED LOADS	12
SECTION 3 DESIGN SITUATIONS	14
3.1 GENERAL	14
3.2 PERMANENT LOADS	14
3.3 IMPOSED LOADS	14
3.3.1 <i>General</i>	14
3.3.2 <i>Additional provisions for buildings</i>	15
SECTION 4 DENSITIES OF CONSTRUCTION AND STORED MATERIALS.....	16
4.1 GENERAL	16
SECTION 5 SELF-WEIGHT OF CONSTRUCTION WORKS.....	17
5.1 REPRESENTATION OF ACTIONS	17
5.2 CHARACTERISTIC VALUES OF SELF-WEIGHT	17
5.2.1 <i>General</i>	17
5.2.2 <i>Additional provisions for buildings</i>	17
5.2.3 <i>Additional provisions specific for bridges</i>	18
SECTION 6 IMPOSED LOADS ON BUILDINGS	19
6.1 REPRESENTATION OF ACTIONS	19
6.2 LOAD ARRANGEMENTS.....	19
6.2.1 <i>Floors, beams and roofs</i>	19
6.2.2 <i>Columns and walls</i>	19
6.3 CHARACTERISTIC VALUES OF IMPOSED LOADS	20
6.3.1 <i>Residential, social, commercial and administration areas</i>	20
6.3.1.1 Categories.....	20
6.3.1.2 Values of actions	21
6.3.2 <i>Areas for storage and industrial activities</i>	24
6.3.2.1 Categories.....	24
6.3.2.2 Values for Actions.....	24
6.3.2.3 Actions induced by forklifts	25
6.3.2.4 Actions induced by transport vehicles.....	26

6.3.2.5 Actions induced by special devices for maintenance.....	27
6.3.3 <i>Garages and vehicle traffic areas (excluding bridges)</i>	27
6.3.3.1 Categories.....	27
6.3.3.2 Values of actions.....	27
6.3.4 <i>Roofs</i>	28
6.3.4.1 Categories.....	28
6.3.4.2 Values of actions.....	29
6.4 HORIZONTAL LOADS ON PARAPETS AND PARTITION WALLS ACTING AS BARRIERS.....	30
LOADED AREAS.....	31
ANNEX A (INFORMATIVE) TABLES FOR NOMINAL DENSITY OF CONSTRUCTION MATERIALS, AND NOMINAL DENSITY AND ANGLES OF REPOSE FOR STORED MATERIALS.....	32
ANNEX B (INFORMATIVE) VEHICLE BARRIERS AND PARAPETS FOR CAR PARKS	43

Foreword

This document (EN 1991-1-1:2002) has been prepared by Technical Committee CEN/TC 250 "Structural Eurocodes", the secretariat of which is held by BSI.

This European Standard shall be given the status of a national standard, either by publication of an identical text or by endorsement, at the latest by October 2002, and conflicting national standards shall be withdrawn at the latest by March 2010.

CEN/TC 250 is responsible for all Structural Eurocodes.

This document supersedes ENV 1991-2-1:1995.

The annexes A and B are informative.

According to the CEN/CENELEC Internal Regulations, the national standards organizations of the following countries are bound to implement this European Standard: Austria, Belgium, Czech Republic, Denmark, Finland, France, Germany, Greece, Iceland, Ireland, Italy, Luxembourg, Malta, Netherlands, Norway, Portugal, Spain, Sweden, Switzerland and the United Kingdom.

Background of the Eurocode programme

In 1975, the Commission of the European Community decided on an action programme in the field of construction, based on article 95 of the Treaty. The objective of the programme was the elimination of technical obstacles to trade and the harmonisation of technical specifications.

Within this action programme, the Commission took the initiative to establish a set of harmonised technical rules for the design of construction works which, in a first stage, would serve as an alternative to the national rules in force in the Member States and, ultimately, would replace them.

For fifteen years, the Commission, with the help of a Steering Committee with Representatives of Member States, conducted the development of the Eurocodes programme, which led to the first generation of European codes in the 1980s.

In 1989, the Commission and the Member States of the EU and EFTA decided, on the basis of an agreement¹ between the Commission and CEN, to transfer the preparation and the publication of the Eurocodes to CEN through a series of Mandates, in order to provide them with a future status of European Standard (EN). This links *de facto* the Eurocodes with the provisions of all the Council's Directives and/or Commission's Decisions dealing with European standards (e.g. the Council Directive 89/106/EEC on

¹ Agreement between the Commission of the European Communities and the European Committee for Standardisation (CEN) concerning the work on EUROCODES for the design of building and civil engineering works (BC/CEN/03/89).

construction products - CPD - and Council Directives 93/37/EEC, 92/50/EEC and 89/440/EEC on public works and services and equivalent EFTA Directives initiated in pursuit of setting up the internal market).

The Structural Eurocode programme comprises the following standards generally consisting of a number of Parts:

EN 1990	Eurocode :	Basis of Structural Design
EN 1991	Eurocode 1:	Actions on structures
EN 1992	Eurocode 2:	Design of concrete structures
EN 1993	Eurocode 3:	Design of steel structures
EN 1994	Eurocode 4:	Design of composite steel and concrete structures
EN 1995	Eurocode 5:	Design of timber structures
EN 1996	Eurocode 6:	Design of masonry structures
EN 1997	Eurocode 7:	Geotechnical design
EN 1998	Eurocode 8:	Design of structures for earthquake resistance
EN 1999	Eurocode 9:	Design of aluminium structures

Eurocode standards recognise the responsibility of regulatory authorities in each Member State and have safeguarded their right to determine values related to regulatory safety matters at national level where these continue to vary from State to State.

Status and field of application of Eurocodes

The Member States of the EU and EFTA recognise that Eurocodes serve as reference documents for the following purposes:

- as a means to prove compliance of building and civil engineering works with the essential requirements of Council Directive 89/106/EEC, particularly Essential Requirement N°1 – Mechanical resistance and stability – and Essential Requirement N°2 – Safety in case of fire ;
- as a basis for specifying contracts for construction works and related engineering services ;
- as a framework for drawing up harmonised technical specifications for construction products (ENs and ETAs)

The Eurocodes, as far as they concern the construction works themselves, have a direct relationship with the Interpretative Documents² referred to in Article 12 of the CPD, although they are of a different nature from harmonised product standards³. Therefore, technical aspects arising from the Eurocodes work need to be adequately considered by

² According to Art. 3.3 of the CPD, the essential requirements (ERs) shall be given concrete form in interpretative documents for the creation of the necessary links between the essential requirements and the mandates for harmonised ENs and ETAGs/ETAs.

³ According to Art. 12 of the CPD the interpretative documents shall :

- a) give concrete form to the essential requirements by harmonising the terminology and the technical bases and indicating classes or levels for each requirement where necessary ;
- b) indicate methods of correlating these classes or levels of requirement with the technical specifications, e.g. methods of calculation and of proof, technical rules for project design, etc. ;
- c) serve as a reference for the establishment of harmonised standards and guidelines for European technical approvals.

The Eurocodes, *de facto*, play a similar role in the field of the ER 1 and a part of ER 2.

BS EN 1991-1-1:2002
EN 1991-1-1:2002 (E)

CEN Technical Committees and/or EOTA Working Groups working on product standards with a view to achieving full compatibility of these technical specifications with the Eurocodes.

The Eurocode standards provide common structural design rules for everyday use for the design of whole structures and component products of both a traditional and an innovative nature. Unusual forms of construction or design conditions are not specifically covered and additional expert consideration will be required by the designer in such cases.

National Standards implementing Eurocodes

The National Standards implementing Eurocodes will comprise the full text of the Eurocode (including any annexes), as published by CEN, which may be preceded by a National title page and National foreword, and may be followed by a National annex.

The National annex may only contain information on those parameters which are left open in the Eurocode for national choice, known as Nationally Determined Parameters, to be used for the design of buildings and civil engineering works to be constructed in the country concerned, *i.e.* :

- values and/or classes where alternatives are given in the Eurocode,
- values to be used where a symbol only is given in the Eurocode,
- country specific data (geographical, climatic, etc.), e.g. snow map,
- the procedure to be used where alternative procedures are given in the Eurocode.

It may also contain

- decisions on the application of informative annexes,
- references to non-contradictory complementary information to assist the user to apply the Eurocode.

Links between Eurocodes and harmonised technical specifications (ENs and ETAs) for products

There is a need for consistency between the harmonised technical specifications for construction products and the technical rules for works⁴. Furthermore, all the information accompanying the CE Marking of the construction products which refer to Eurocodes should clearly mention which Nationally Determined Parameters have been taken into account.

Additional information specific for EN 1991-1-1

EN 1991-1-1 gives design guidance and actions for the structural design of buildings and civil engineering works, including the following aspects:

- densities of construction materials and stored materials ;
- self-weight of construction elements, and
- imposed loads for buildings.

⁴ see Art.3.3 and Art.12 of the CPD, as well as clauses 4.2, 4.3.1, 4.3.2 and 5.2 of ID 1.

EN 1991-1-1 is intended for clients, designers, contractors and public authorities.

EN 1991-1-1 is intended to be used with EN 1990, the other Parts of EN 1991 and EN 1992 to EN 1999 for the design of structures.

National annex for EN 1991-1-1

This standard gives alternative procedures, values and recommendations for classes with notes indicating where National choices have to be made, therefore the National Standard implementing EN 1991-1-1 should have a National Annex containing all Nationally Determined Parameters to be used for the design of buildings and civil engineering works to be constructed in the relevant country.

National choice is allowed in EN 1991-1-1 through:

- ▣_{AC1} – 2.2(3),
- 5.2.3(1) to 5.2.3(5),
- 6.3.1.1(1)P (Table 6.1),
- 6.3.1.2(1)P (Table 6.2),
- 6.3.1.2(10) & (11),
- 6.3.2.2 (1)P (Table 6.4),
- 6.3.3.2(1) (Table 6.8),
- 6.3.4.2(1) (Table 6.10)
- 6.4 (1) (Table 6.12) ▣_{AC1}

Section 1 General

1.1 Scope

(1) EN 1991-1-1 gives design guidance and actions for the structural design of buildings and civil engineering works including some geotechnical aspects for the following subjects:

- Densities of construction materials and stored materials;
- Self-weight of construction works;
- Imposed loads for buildings.

(2) Section 4 and Annex A give nominal values for densities of specific building materials, additional materials for bridges and stored materials. In addition for specific materials the angle of repose is provided.

(3) Section 5 provides methods for the assessment of the characteristic values of self-weight of construction works.

(4) Section 6 gives characteristic values of imposed loads for floors and roofs according to category of use in the following areas in buildings:

- residential, social, commercial and administration areas;
- garage and vehicle traffic areas;
- areas for storage and industrial activities;
- roofs;
- helicopter landing areas.

(5) The loads on traffic areas given in Section 6 refer to vehicles up to a gross vehicle weight of 160 kN. The design for traffic areas for heavy vehicles of more than 160 kN gross weight needs to be agreed with the relevant authority. Further information may be obtained from EN 1991-2.

(6) For barriers or walls having the function of barriers, horizontal forces are given in Section 6. Annex B gives additional guidance for vehicle barriers in car parks.

NOTE Forces due to vehicle impact are specified in EN 1991-1-7 and EN 1991-2.

(7) For the design situations and effects of actions in silos and tanks caused by water or other materials see EN 1991-3.

1.2 Normative References

This European Standard incorporates by dated or undated reference provisions from other publications. These normative references are cited at the appropriate places in the text and the publications are listed hereafter. For dated references, subsequent amendments to, or revisions of, any of these publications apply to this European Standard only when incorporated in it by amendment or revision. For undated references the latest edition of the publication referred to applies (including amendments).

NOTE 1 The Eurocodes were published as European Prestandards. The following European Standards which are published or in preparation are cited in normative clauses :

EN 1990	Eurocode : Basis of Structural Design
EN 1991-1-7	Eurocode 1: Actions on structures: Part 1-7: Accidental actions from impact and explosions
EN 1991-2	Eurocode 1: Actions on structures: Part 2: Traffic loads on bridges
EN 1991-3	Eurocode 1: Actions on structures: Part 3: Actions induced by cranes and machinery
EN 1991-4	Eurocode 1: Actions on structures: Part 4: Actions in silos and tanks

NOTE 2 The Eurocodes were published as European Prestandards. The following European Standards which are published or in preparation are cited in NOTES to normative clauses :

EN 1991-1-3	Eurocode 1: Actions on structures: Part 1-3: Snow loads
EN 1991-1-4	Eurocode 1: Actions on structures: Part 1-4: Wind actions
EN 1991-1-6	Eurocode 1: Actions on structures: Part 1-6: Actions during execution

1.3 Distinction between Principles and Application Rules

(1) Depending on the character of the individual clauses, distinction is made in this Part between Principles and Application Rules.

(2) The Principles comprise:

- general statements and definitions for which there is no alternative, as well as
- requirements and analytical models for which no alternative is permitted unless specifically stated.

(3) The Principles are identified by the letter P following the paragraph number.

(4) The Application Rules are generally recognised rules which comply with the Principles and satisfy their requirements.

(5) It is permissible to use alternative design rules different from the Application Rules given in EN 1991-1-1 for works, provided that it is shown that the alternative rules accord with the relevant Principles and are at least equivalent with regard to the structural safety, serviceability and durability which would be expected when using the Eurocodes.

NOTE If an alternative design rule is substituted for an Application Rule, the resulting design cannot be claimed to be wholly in accordance with EN 1991-1-1 although the design will remain in accordance with

BS EN 1991-1-1:2002
EN 1991-1-1:2002 (E)

the Principles of EN 1991-1-1. When EN 1991-1-1 is used in respect of a property listed in an Annex Z of a product standard or an ETAG, the use of an alternative design rule may not be acceptable for CE marking.

(6) In this Part the Application Rules are identified by a number in brackets, e.g. as this clause.

1.4 Terms and definitions

For the purposes of this European Standard, the terms and definitions given in ISO 2394, ISO 3898, ISO 8930 and the following apply. Additionally for the purposes of this standard a basic list of terms and definitions is provided in EN 1990, 1.5.

1.4.1

bulk weight density

the bulk weight density is the overall weight per unit volume of a material, including a normal distribution of micro-voids, voids and pores

NOTE: In everyday usage this term is frequently abbreviated to “density” (which is strictly mass per unit volume).

1.4.2

angle of repose

the angle of repose is the angle which the natural slope of the sides of a heaped pile of loose material makes to the horizontal

1.4.3

gross weight of vehicle

the gross weight of a vehicle includes the self-weight of the vehicle together with the maximum weight of the goods it is permitted to carry

1.4.4

structural elements

structural elements comprise the primary structural frame and supporting structures. For bridges, structural elements comprise girders, structural slabs and elements providing support such as cable stays

1.4.5

non structural elements

non structural elements are those that include completion and finishing elements connected with the structure, including road surfacing and non-structural parapets. They also include services and machinery fixed permanently to, or within, the structure

1.4.6

partitions

non load bearing walls

1.4.7

movable partitions

movable partitions are those which can be moved on the floor, be added or removed or re-built at another place

1.5 Symbols

(1) For the purposes of this European standard, the following symbols apply.

NOTE The notation used is based on ISO 3898: 1997.

(2) A basic list of symbols is provided in EN 1990 clause 1.6 and the additional notations below are specific to this part of EN 1991.

Latin upper case letters

A	loaded area
A_0	basic area
Q_k	characteristic value of a variable concentrated load

Latin lower case letters

g_k	weight per unit area, or weight per unit length
n	number of storeys
q_k	characteristic value of a uniformly distributed load, or line load

Lower case Greek letters

α_A	reduction factor
α_n	reduction factor
γ	bulk weight density
φ	dynamic magnification factor
ψ_0	factor for combination value of a variable action, see table A.1.1 of EN 1990
ϕ	angle of repose (degrees)

Section 2 Classification of actions

2.1 Self-weight

(1) The self-weight of construction works should be classified as a permanent fixed action, see EN 1990, 1.5.3 and 4.1.1.

(2) Where this self-weight can vary in time, it should be taken into account by the upper and lower characteristic values (see EN 1990, 4.1.2). However, in some cases where it is free (e.g. for movable partitions, see 6.3.1.2(8)), it should be treated as an additional imposed load.

NOTE This applies in particular when the "permanent" actions may be favourable.

(3)P The loads due to ballast shall be considered as permanent actions and possible redistributions of ballast shall be taken into account in the design, see 5.2.2 (1) and (2).

(4)P The earth loads on roofs and terraces shall be considered as permanent actions.

(5) With regard to 2.1(3)P and 2.1(4)P, the design should consider variations in moisture content and variation in depth, that may be caused by uncontrolled accumulation during the design life of the structure.

NOTE For detailed information on earth pressures see EN 1997.

2.2 Imposed loads

(1)P Imposed loads shall be classified as variable free actions, unless otherwise specified in this standard, see EN 1990, 1.5.3 and 4.1.1.

NOTE For imposed loads on bridges see EN 1991-2.

(2) When considering the accidental design situation where impact from vehicles or accidental loads from machines may be relevant, these loads should be taken from EN 1991-1-7.

(3) Imposed loads should be taken into account as quasi-static actions (see EN 1990, 1.5.3.13). The load models may include dynamic effects if there is no risk of resonance or other significant dynamic response of the structure, see EN 1992 to EN 1999. If resonance effects from synchronised rhythmic movement of people or dancing or jumping may be expected, the load model should be determined for special dynamic analysis.

NOTE The procedure to be used may be given in the National annex.

(4) When considering forklifts and helicopters, the additional loadings due to masses and inertial forces caused by fluctuating effects should be considered. These effects are taken into account by a dynamic magnification factor ϕ which is applied to the static load values, as shown in expression (6.3).

(5)P Actions which cause significant acceleration of the structure or structural members shall be classified as dynamic actions and shall be considered using a dynamic analysis.

Section 3 Design situations

3.1 General

(1)P The relevant permanent and imposed loads shall be determined for each design situation identified in accordance with EN 1990, 3.2.

3.2 Permanent loads

(1) The total self-weight of structural and non-structural members should be taken into account in combinations of actions as a single action.

NOTE See EN 1990 Table A1.2 (B) Note 3.

(2) For areas where it is intended to remove or add structural or non-structural elements, the critical load cases should be taken into account in the design.

(3) The self-weight of new coatings and/or distribution conduits that are intended to be added after execution should be taken into account in design situations (see 5.2).

(4)P The water level shall be taken into account for the relevant design situations.

NOTE See EN 1997.

(5) The source and moisture content of bulk materials should be considered in design situations of buildings used for storage purposes.

NOTE The values for the densities provided in Annex A are for materials in the dry state.

3.3 Imposed loads

3.3.1 General

(1)P For areas which are intended to be subjected to different categories of loadings the design shall consider the most critical load case.

(2)P In design situations when imposed loads act simultaneously with other variable actions (e.g. actions induced by wind, snow, cranes or machinery), the total imposed loads considered in the load case shall be considered as a single action.

(3) Where the number of load variations or the effects of vibrations may cause fatigue, a fatigue load model should be established.

(4) For structures susceptible to vibrations, dynamic models of imposed loads should be considered where relevant. The design procedure is given in EN 1990 clause 5.1.3.

3.3.2 Additional provisions for buildings

AC1 (1) On roofs (particularly for category H roofs), imposed loads, need not be applied in combination with either snow loads and/or wind actions. AC1

(2)P When the imposed load is considered as an accompanying action, in accordance with EN 1990, only one of the two factors ψ (EN 1990, Table A1.1) and α_n (6.3.1.2 (11)) shall be applied.

(3) For dynamic loads caused by machinery see EN 1991-3.

(4) The imposed loads to be considered for serviceability limit state verifications should be specified in accordance with the service conditions and the requirements concerning the performance of the structure.

Section 4 Densities of construction and stored materials

4.1 General

(1) Characteristic values of densities of construction and stored materials should be specified. Mean values should be used as characteristic values. See however 4.1(2) and 4.1(3).

NOTE Annex A gives mean values for densities and angles of repose for stored materials. When a range is given it is assumed that the mean value will be highly dependent on the source of the material and may be selected considering each individual project.

(2) For materials (*e.g.* new and innovative materials) which are not covered by the Tables in Annex A, the characteristic value of the density should be determined in accordance with EN 1990 clause 4.1.2 and agreed for each individual project.

(3) Where materials are used with a significant scatter of densities *e.g.* due to their source, water content etc, the characteristic value of these densities should be assessed in accordance with EN 1990 clause 4.1.2.

(4) If a reliable direct assessment of the densities is carried out, then these values may be used.

NOTE EN 1990 Annex D may be used.

Section 5 Self-weight of construction works

5.1 Representation of actions

(1) The self-weight of the construction works should in most cases, be represented by a single characteristic value and be calculated on the basis of the nominal dimensions and the characteristic values of the densities.

(2) The self weight of the construction works includes the structure and non-structural elements including fixed services as well as the weight of earth and ballast.

(3) Non-structural elements include:

- roofing ;
- surfacing and coverings ;
- partitions and linings ;
- hand rails, safety barriers, parapets and kerbs ;
- wall cladding ;
- suspended ceilings
- thermal insulation ;
- bridge furniture;
- fixed services (see 5.1.(4)).

NOTE For information on fixed machinery see EN 1991-3. For other industrial equipment (e.g. safes) the manufacturer should be consulted.

(4) Fixed services include :

- equipments for lifts and moving stairways ;
- heating, ventilating and air conditioning equipment ;
- electrical equipment ;
- pipes without their contents ;
- cable trunking and conduits.

(5)P Loads due to movable partitions shall be treated as imposed loads, see 5.2.2(2)P and 6.3.1.2(8).

5.2 Characteristic values of self-weight

5.2.1 General

(1)P The determination of the characteristic values of self-weight, and of the dimensions and densities shall be in accordance with EN 1990, 4.1.2.

(2) Nominal dimensions should be those as shown on the drawings.

5.2.2 Additional provisions for buildings

(1) For manufactured elements such as flooring systems, facades and ceilings, lifts and equipment for buildings, data may be provided by the manufacturer.

(2)P For determining the effect of the self-weight due to movable partitions, an equivalent uniformly distributed load shall be used and added to the imposed load, see 6.3.1.2 (8).

5.2.3 Additional provisions specific for bridges

(1) The upper and lower characteristic values of densities for non structural parts, such as ballast on railway bridges, or fill above buried structures such as culverts, should be taken into account if the material is expected to consolidate, become saturated or otherwise change its properties, during use.

NOTE Suitable values may be given in the National annex.

(2) The nominal depth of ballast on railway bridges should be specified. To determine the upper and lower characteristic values of the depth of ballast on railway bridges a deviation from the nominal depth of $\pm 30\%$ should be taken into account.

NOTE A suitable value may be given in the National annex

(3) To determine the upper and lower characteristic values of self-weight of waterproofing, surfacing and other coatings for bridges, where the variability of their thickness may be high, a deviation of the total thickness from the nominal or other specified values should be taken into account. Unless otherwise specified, this deviation should be taken equal to $\pm 20\%$ if a post-execution coating is included in the nominal value, and to $+40\%$ and -20% if such a coating is not included.

NOTE Suitable specifications may be given in the National annex.

(4) For the self-weight of cables, pipes and service ducts, the upper and lower characteristic values should be taken into account. Unless otherwise specified, a deviation from the mean value of the self-weight of $\pm 20\%$ should be taken into account.

NOTE Suitable specifications may be given in the National annex. See also EN 1990, 4.1.2(4)

(5) For the self-weight of other non structural elements such as :

- hand rails, safety barriers, parapets, kerbs and other bridge furniture,
- joints/fasteners,
- void formers,

the characteristic values should be taken equal to the nominal values unless otherwise specified.

NOTE Suitable specifications may be given in the National annex. An allowance for voids filling with water may be made depending on the project.

Section 6 Imposed loads on buildings

6.1 Representation of actions

(1) Imposed loads on buildings are those arising from occupancy. Values given in this Section, include:

- normal use by persons;
- furniture and moveable objects (e.g. moveable partitions, storage, the contents of containers);
- vehicles;
- anticipating rare events, such as concentrations of persons or of furniture, or the moving or stacking of objects which may occur during reorganization or redecoration.

(2) The imposed loads specified in this part are modelled by uniformly distributed loads, line loads or concentrated loads or combinations of these loads.

(3) For the determination of the imposed loads, floor and roof areas in buildings should be sub-divided into categories according to their use.

(4) Heavy equipment (e.g. in communal kitchens, radiology rooms, boiler rooms etc) are not included in the loads given in this Section. Loads for heavy equipment should be agreed between the client and/or the relevant Authority.

6.2 Load arrangements

6.2.1 Floors, beams and roofs

(1)P For the design of a floor structure within one storey or a roof, the imposed load shall be taken into account as a free action applied at the most unfavourable part of the influence area of the action effects considered.

(2) Where the loads on other storeys are relevant, they may be assumed to be distributed uniformly (fixed actions).

(3)P To ensure a minimum local resistance of the floor structure a separate verification shall be performed with a concentrated load that, unless stated otherwise, shall not be combined with the uniformly distributed loads or other variable actions.

(4) Imposed loads from a single category may be reduced according to the areas supported by the appropriate member, by a reduction factor α_A according to 6.3.1.2(10).

6.2.2 Columns and walls

AC1 (1) For the design of columns and walls, the imposed load should be placed at all unfavourable locations.

NOTE The National Annex may introduce further simplifying rules. It is recommended that the maximum axial force may be calculated assuming the total imposed load on the floor of each story to be uniformly distributed. **AC1**

(2) Where imposed loads from several storeys act on columns and walls, the total imposed loads may be reduced by a factor α_n according to 6.3.1.2(11) and 3.3.1(2)P.

6.3 Characteristic values of Imposed Loads

6.3.1 Residential, social, commercial and administration areas

6.3.1.1 Categories

(1)P Areas in residential, social, commercial and administration buildings shall be divided into categories according to their specific uses shown in Table 6.1.

(2)P Independent of this classification of areas, dynamic effects shall be considered where it is anticipated that the occupancy will cause significant dynamic effects (see 2.2(3) and (5)P).

Table 6.1 - Categories of use

Category	Specific Use	Example
A	Areas for domestic and residential activities	Rooms in residential buildings and houses; bedrooms and wards in hospitals; bedrooms in hotels and hostels kitchens and toilets.
B	Office areas	
C	Areas where people may congregate (with the exception of areas defined under category A, B, and D ¹⁾)	<p>C1: Areas with tables, etc. e.g. areas in schools, cafés, restaurants, dining halls, reading rooms, receptions.</p> <p>C2: Areas with fixed seats, e.g. areas in churches, theatres or cinemas, conference rooms, lecture halls, assembly halls, waiting rooms, railway waiting rooms.</p> <p>C3: Areas without obstacles for moving people, e.g. areas in museums, exhibition rooms, etc. and access areas in public and administration buildings, hotels, hospitals, railway station forecourts.</p> <p>C4: Areas with possible physical activities, e.g. dance halls, gymnastic rooms, stages.</p> <p>C5: Areas susceptible to large crowds, e.g. in buildings for public events like concert halls, sports halls including stands, terraces and access areas and railway platforms.</p>
D	Shopping areas	<p>D1: Areas in general retail shops</p> <p>D2: Areas in department stores</p>
<p>¹⁾ Attention is drawn to 6.3.1.1(2), in particular for C4 and C5. See EN 1990 when dynamic effects need to be considered. For Category E, see Table 6.3</p> <p>NOTE 1 Depending on their anticipated uses, areas likely to be categorised as C2, C3, C4 may be categorised as C5 by decision of the client and/or National annex.</p> <p>NOTE 2 The National annex may provide sub categories to A, B, C1 to C5, D1 and D2</p> <p>NOTE 3 See 6.3.2 for storage or industrial activity</p>		

6.3.1.2 Values of actions

(1)P The categories of loaded areas, as specified in Table 6.1, shall be designed by using characteristic values q_k (uniformly distributed load) and Q_k (concentrated load).

NOTE Values for q_k and Q_k are given in Table 6.2 below. Where a range is given in this table, the value may be set by the National annex. The recommended values, intended for separate application, are underlined. q_k is intended for determination of general effects and Q_k for local effects. The National annex may define different conditions of use of this Table.

Table 6.2 - Imposed loads on floors, balconies and stairs in buildings

Categories of loaded areas	q_k [kN/m ²]	Q_k [kN]
Category A		
- Floors	1,5 to <u>2,0</u>	<u>2,0</u> to 3,0
- Stairs	<u>2,0</u> to 4,0	<u>2,0</u> to 4,0
- Balconies	<u>2,5</u> to 4,0	<u>2,0</u> to 3,0
Category B	2,0 to <u>3,0</u>	1,5 to <u>4,5</u>
Category C		
- C1	2,0 to <u>3,0</u>	3,0 to <u>4,0</u>
- C2	3,0 to <u>4,0</u>	2,5 to 7,0 (<u>4,0</u>)
- C3	3,0 to <u>5,0</u>	<u>4,0</u> to 7,0
- C4	4,5 to <u>5,0</u>	3,5 to <u>7,0</u>
- C5	<u>5,0</u> to 7,5	3,5 to <u>4,5</u>
category D		
- D1	<u>4,0</u> to 5,0	3,5 to 7,0 (<u>4,0</u>)
- D2	4,0 to <u>5,0</u>	3,5 to <u>7,0</u>

(2) Where necessary q_k and Q_k should be increased in the design (e.g. for stairs and balconies depending on the occupancy and on dimensions).

(3) For local verifications a concentrated load Q_k acting alone should be taken into account.

(4) For concentrated loads from storage racks or from lifting equipment, Q_k should be determined for the individual case, see 6.3.2.

(5)P The concentrated load shall be considered to act at any point on the floor, balcony or stairs over an area with a shape which is appropriate to the use and form of the floor.

NOTE The shape may normally be assumed as a square with a width of 50 mm. See also 6.3.4.2(4)

(6)P The vertical loads on floors due to traffic of forklifts shall be taken into account according to 6.3.2.3.

(7)P Where floors are subjected to multiple use, they shall be designed for the most unfavourable category of loading which produces the highest effects of actions (e.g. forces or deflection) in the member under consideration.

(8) Provided that a floor allows a lateral distribution of loads, the self-weight of movable partitions may be taken into account by a uniformly distributed load q_k which should be added to the imposed loads of floors obtained from Table 6.2. This defined uniformly distributed load is dependent on the self-weight of the partitions as follows:

– for movable partitions with a self-weight $\leq 1,0$ kN/m wall length: $q_k = 0,5$ kN/m²;

- AC1) – for movable partitions with a self-weight $> 1 \leq 2,0$ kN/m wall length: $q_k = 0,8$ kN/m²;
 – for movable partitions with a self-weight $> 2 \leq 3,0$ kN/m wall length: $q_k = 1,2$ kN/m². AC1)

- (9) Heavier partitions should be considered in the design taking account of:
 – the locations and directions of the partitions;
 – the structural form of the floors.

- AC1) (10) In accordance with 6.2.1(4) a reduction factor α_A may be applied to the q_k values for imposed loads for floors (see Table 6.2 and subclauses (8) and (9)) and for accessible roofs, Category I (see Table 6.9). AC1)

AC1) NOTE 1 The recommended value for the reduction factor α_A for categories A to D is determined as follows: AC1)

$$\alpha_A = \frac{5}{7} \psi_0 + \frac{A_0}{A} \leq 1,0 \quad (6.1)$$

with the restriction for categories C and D: $\alpha_A \geq 0,6$

where:

ψ_0 is the factor according to EN 1990 Annex A1 Table A1.1

$$A_0 = 10,0 \text{ m}^2$$

A is the loaded area

NOTE 2 The National Annex may give an alternative method.

- (11) In accordance with 6.2.2(2) and provided that the area is classified according to table 6.1 into the categories A to D, for columns and walls the total imposed loads from several storeys may be multiplied by the reduction factor α_n .

NOTE 1 The recommended values for α_n are given below.

$$\alpha_n = \frac{2 + (n - 2)\psi_0}{n} \quad (6.2)$$

where:

n is the number of storeys (> 2) above the loaded structural elements from the same category.

ψ_0 is in accordance with EN 1990, Annex A1, Table A1.1.

NOTE 2 The National annex may give an alternative method.

6.3.2 Areas for storage and industrial activities

6.3.2.1 Categories

(1)P Areas for storage and industrial activities shall be divided into the two categories according to Table 6.3.

Table 6.3 -Categories of storage and industrial use

Category	Specific use	Example
E1	Areas susceptible to accumulation of goods, including access areas	Areas for storage use including storage of books and other documents.
E2	Industrial use	

6.3.2.2 Values for Actions

(1)P The loaded areas, categorized as specified in Table 6.3, shall be designed by using characteristic values q_k (uniformly distributed load) and Q_k (concentrated load).

NOTE Recommended values for q_k and Q_k are given in Table 6.4 below. The values may be changed if necessary according to the usage (see Table 6.3 and Annex A) for the particular project or by the National annex. q_k is intended for determination of general effects and Q_k for local effects. The National annex may define different conditions of use of Table 6.4.

Table 6.4 - Imposed loads on floors due to storage

Categories of loaded areas	q_k [kN/m ²]	Q_k [kN]
Category E1	7,5	7,0

(2)P The characteristic value of the imposed load shall be the maximum value taking account of the dynamic effects if appropriate. The loading arrangement shall be defined so that it produces the most unfavourable conditions allowed in use.

NOTE For transient design situations due to installation and reinstallation of machines, production units etc. guidance is given in EN 1991-1-6.

(3) The characteristic values of vertical loads in storage areas should be derived by taking into account the density and the upper design values for stacking heights. When stored material exerts horizontal forces on walls etc., the horizontal force should be determined in accordance with EN 1991-4.

NOTE See Annex A for densities.

(4) Any effects of filling and emptying should be taken into account.

(5) Loads for storage areas for books and other documents should be determined from the loaded area and the height of the book cases using the appropriate values for density.

(6) Loads in industrial areas should be assessed considering the intended use and the equipment which is to be installed. Where equipment such as cranes, moving machinery etc, are to be installed the effects on the structure should be determined in accordance with EN 1991-3.

(7) Actions due to forklifts and transport vehicles should be considered as concentrated loads acting together with the appropriate imposed distributed loads given in Tables 6.2, 6.4. and 6.8.

6.3.2.3 Actions induced by forklifts

(1) Forklifts should be classified in 6 classes FL 1 to FL 6 depending on net weight, dimensions and hoisting loads, see Table 6.5.

Table 6.5 - Dimensions of forklift according to classes FL

Class of Forklift	Net weight [kN]	Hoisting load [kN]	Width of axle a [m]	Overall width b [m]	Overall length l [m]
FL 1	21	10	0,85	1,00	2,60
FL 2	31	15	0,95	1,10	3,00
FL 3	44	25	1,00	1,20	3,30
FL 4	60	40	1,20	1,40	4,00
FL 5	90	60	1,50	1,90	4,60
FL 6	110	80	1,80	2,30	5,10

(2) The static vertical axle load Q_k of a forklift depends on the forklift classes FL1 to FL6 and should be obtained from Table 6.6.

Table 6.6 - Axle loads of forklifts

Class of forklifts	Axle load Q_k [kN]
FL 1	26
FL 2	40
FL 3	63
FL 4	90
FL 5	140
FL 6	170

(3) The static vertical axle load Q_k should be increased by the dynamic factor φ using expression (6.3).

$$Q_{k,dyn} = \varphi Q_k \quad (6.3)$$

whre:

$Q_{k,dyn}$ is the dynamic characteristic value of the action;

φ is the dynamic magnification factor;
 Q_k is the static characteristic value of the action.

(4) The dynamic factor φ for forklifts takes into account the inertial effects caused by acceleration and deceleration of the hoisting load and should be taken as:

$\varphi = 1,40$ for pneumatic tyres,
 $\varphi = 2,00$ for solid tyres.

(5) For forklifts having a net weight greater than 110 kN the loads should be defined by a more accurate analysis.

(6) The vertical axle load Q_k and $Q_{k,dyn}$ of a forklift should be arranged according to Figure 6.1.

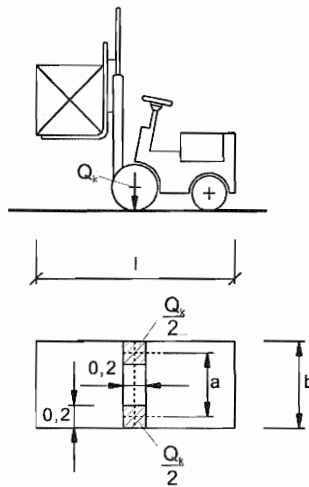

Figure 6.1 - Dimensions of forklifts

(7) Horizontal loads due to acceleration or deceleration of forklifts may be taken as 30 % of the vertical axle loads Q_k .

NOTE Dynamic factors need not be applied.

6.3.2.4 Actions induced by transport vehicles

(1) The actions from transport vehicles that move on floors freely or guided by rails should be determined by a pattern of wheel loads.

(2) The static values of the vertical wheel loads should be given in terms of permanent weights and pay loads. Their spectra should be used to define combination factors and fatigue loads.

(3) The vertical and horizontal wheel loads should be determined for the specific case.

(4) The load arrangement including the dimensions relevant for the design should be determined for the specific case.

NOTE Appropriate load models from EN 1991-2 may be used where relevant.

6.3.2.5 Actions induced by special devices for maintenance

(1) Special devices for maintenance should be modelled as loads from transportation vehicles, see 6.3.2.4.

(2) The load arrangements including the dimensions relevant for the design should be determined for the specific case.

6.3.3 Garages and vehicle traffic areas (excluding bridges)

6.3.3.1 Categories

(1)P Traffic and parking areas in buildings shall be divided into two categories according to their accessibility for vehicles as shown in Table 6.7.

Table 6.7 - Traffic and parking areas in buildings

Categories of traffic areas	Specific Use	Examples
F	Traffic and parking areas for light vehicles (≤ 30 kN gross vehicle weight and ≤ 8 seats not including driver)	garages; parking areas, parking halls
G	Traffic and parking areas for medium vehicles (>30 kN, ≤ 160 kN gross vehicle weight, on 2 axles)	access routes; delivery zones; zones accessible to fire engines (≤ 160 kN gross vehicle weight)
NOTE 1 Access to areas designed to category F should be limited by physical means built into the structure.		
NOTE 2 Areas designed to categories F and G should be posted with the appropriate warning signs.		

6.3.3.2 Values of actions

(1) The load model which should be used is a single axle with a load Q_k with dimensions according to Figure 6.2 and a uniformly distributed load q_k . The characteristic values for q_k and Q_k are given in Table 6.8.

NOTE q_k is intended for determination of general effects and Q_k for local effects. The National annex may define different conditions of use of this Table.

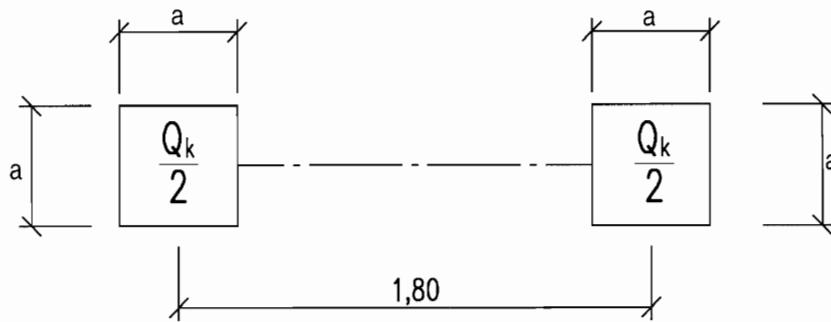

NOTE For category F (see Table 6.8) the width of the square surface is 100 mm and for category G (see Table 6.8) the width of a square surface is 200 mm.

Figure 6.2 - Dimensions of axle load

Table 6.8 - Imposed loads on garages and vehicle traffic areas

Categories of traffic areas	q_k [kN/m ²]	Q_k [kN]
Category F Gross vehicle weight: ≤ 30 kN	q_k	Q_k
Category G $30 \text{ kN} < \text{gross vehicle weight} \leq 160$ kN	5,0	Q_k
NOTE 1 For category F, q_k may be selected within the range 1,5 to <u>2,5</u> kN/m ² and Q_k may be selected within the range 10 to <u>20</u> kN.		
NOTE 2 For category G, Q_k may be selected within the range 40 to <u>90</u> kN.		
NOTE 3 Where a range of values are given in Notes 1 & 2, the value may be set by the National annex. The recommended values are underlined.		

(2) The axle load should be applied on two square surfaces with a 100 mm side for category F and a 200 mm side for Category G in the possible positions which will produce the most adverse effects of the action.

6.3.4 Roofs

6.3.4.1 Categories

(1)P Roofs shall be categorised according to their accessibility into three categories as shown in Table 6.9.

Table 6.9 - Categorization of roofs

Categories of loaded area	Specific Use
H	Roofs not accessible except for normal maintenance and repair.
I	Roofs accessible with occupancy according to categories A to G_{AC1}
K	Roofs accessible for special services, such as helicopter landing areas

(2) Imposed loads for roofs of category H should be those given in Table 6.10. Imposed loads for roofs of category I are given in Tables 6.2, 6.4 and 6.8 according to the specific use.

(3) The loads for roofs of category K which provide areas for helicopter landing areas should be for the helicopter classes HC, see Table 6.11.

6.3.4.2 Values of actions

(1) For roofs of category H the minimum characteristic values Q_k and q_k that should be used are given in Table 6.10. They are related to the projected area of the roof under consideration.

NOTE The values for q_k in Table 6.12 may be chosen by the National Annex. The recommended values are underlined.

Table 6.10 - Imposed loads on roofs of category H

Roof	q_k [kN/m ²]	Q_k [kN]
Category H	q_k	Q_k
NOTE 1 For category H q_k may be selected within the range 0,00 kN/m ² to 1,0 kN/m ² and Q_k may be selected within the range 0,9 kN to 1,5 kN.		
Where a range is given the values may be set by the National Annex. The recommended values are:		
$q_k = 0,4 \text{ kN/m}^2, Q_k = 1,0 \text{ kN}$		
NOTE 2 q_k may be varied by the National Annex dependent upon the roof slope.		
NOTE 3 q_k may be assumed to act on an area A which may be set by the National Annex. The recommended value for A is 10 m ² , within the range of zero to the whole area of the roof.		
NOTE 4 See also 3.3.2 (1)		

(2) The minimum values given in Table 6.10 do not take into account uncontrolled accumulations of construction materials that may occur during maintenance.

NOTE See also EN 1991-1-6: Actions during execution.

(3)P For roofs separate verifications shall be performed for the concentrated load Q_k and the uniformly distributed load q_k , acting independently.

(4) Roofs, other than those with roof sheeting, should be designed to resist 1,5 kN on an area based on a 50 mm sided square. Roof elements with a profiled or discontinuously laid surface, should be designed so that the concentrated load Q_k acts over the effective area provided by load spreading arrangements.

(5) For roofs of category K the actions from helicopters on landing areas should be determined in accordance with Table 6.11, and using the dynamic factors given in 6.3.4.2 (6) and expression 6.3

Table 6.11 - Imposed loads on roofs of category K for helicopters

Class of Helicopter	Take-off load Q of helicopter	Take-off load Q_k	Dimension of the loaded area (m x m)
HC1	$Q \leq 20$ kN	$Q_k = 20$ kN	0,2 x 0,2
HC2	$20 \text{ kN} < Q \leq 60$ kN	$Q_k = 60$ kN	0,3 x 0,3

(6) The dynamic factor φ to be applied to the take off load Q_k to take account of impact effects may be taken as $\varphi = 1,40$.

(7) Access ladders and walkways should be assumed to be loaded according to Table 6.10 for a roof slope $< 20^\circ$. For walkways which are part of a designated escape route, q_k should be according to Table 6.2. For walkways for service a minimum characteristic value Q_k of 1,5 kN should be taken.

(8) The following loads should be used for the design of frames and coverings of access hatches (other than glazing), the supports of ceilings and similar structures :

- a) without access: no imposed load;
- b) with access: 0,25 kN/m² distributed over the whole area or the area supported, and the concentrated load of 0,9 kN so placed so as to produce maximum stresses in the affected member.

6.4 Horizontal loads on parapets and partition walls acting as barriers

(1) The characteristic values of the line load q_k acting at the height of the partition wall or parapets but not higher than 1,20 m should be taken from Table 6.12.

NOTE The values for q_k in Table 6.12 may be chosen by the National Annex. The recommended values are underlined. **AC1**

Table 6.12 - Horizontal loads on partition walls and parapets

Loaded areas	q_k [kN/m]
Category A	q_k
Category B and C1	q_k
Categories C2 –to C4 and D	q_k
Category C5	q_k
Category E	See Annex B
Category F	See Annex B
Category G	See Annex B
<p>NOTE 1 For categories A, B and C1, q_k may be selected within the range 0,2 to 1,0 (0,5).</p> <p>NOTE 2 For categories C2 to C4 and D q_k may be selected within the range 0,8 kN/m –to <u>1,0</u> kN/m.</p> <p>NOTE 3 For category C5 q_k may be selected within the range <u>3,0</u> kN/m to 5,0 kN/m.</p> <p>NOTE 4 For category E q_k may be selected within the range 0,8 kN/m to <u>2,0</u> kN/m. For areas of category E the horizontal loads depend on the occupancy. Therefore the value of q_k is defined as a minimum value and should be checked for the specific occupancy.</p> <p>NOTE 5 Where a range of values is given in Notes 1, 2, 3 and 4, the value may be set by the National Annex. The recommended value is underlined.</p> <p>NOTE 6 The National Annex may prescribe additional point loads Q_k and/or hard or soft body impact specifications for analytical or experimental verification.</p>	

(2) For areas susceptible to significant overcrowding associated with public events e.g. for sports stadia, stands, stages, assembly halls or conference rooms, the line load should be taken according to category C5.

Annex A
(informative)

Tables for nominal density of construction materials, and nominal density and angles of repose for stored materials

Table A.1 - Construction materials-concrete and mortar

Materials	Density γ [kN/m ³]
<p>concrete (see EN 206)</p> <p>lightweight</p> <p>density class LC 1,0</p> <p>density class LC 1,2</p> <p>density class LC 1,4</p> <p>density class LC 1,6</p> <p>density class LC 1,8</p> <p>density class LC 2,0</p> <p>normal weight</p> <p>heavy weight</p> <p>mortar</p> <p>cement mortar</p> <p>gypsum mortar</p> <p>lime-cement mortar</p> <p>lime mortar</p>	<p>9,0 to 10,0 ¹⁾²⁾</p> <p>10,0 to 12,0 ¹⁾²⁾</p> <p>12,0 to 14,0 ¹⁾²⁾</p> <p>14,0 to 16,0 ¹⁾²⁾</p> <p>16,0 to 18,0 ¹⁾²⁾</p> <p>18,0 to 20,0 ¹⁾²⁾</p> <p>24,0 ¹⁾²⁾</p> <p>> ¹⁾²⁾</p> <p>19,0 to 23,0</p> <p>12,0 to 18,0</p> <p>18,0 to 20,0</p> <p>12,0 to 18,0</p>
<p>¹⁾ Increase by 1kN/m³ for normal percentage of reinforcing and pre-stressing steel</p>	
<p>²⁾ Increase by 1kN/m³ for unhardened concrete</p>	
<p>NOTE See Section 4</p>	

Table A.2 - Construction materials-masonry

Materials	Density γ [kN/m ³]
masonry units	
clay masonry units	AC1 see EN 771-1
calcium silicate masonry units	see EN 771-2
aggregate concrete masonry units	see EN 771-3
autoclaved aerated masonry units	see EN 771-4
manufactured stone masonry units	see EN 771-5
glass blocks, hollow	see EN 1051 AC1
terra cotta	21,0
natural stones, see prEN 771-6	
granite, syenite, porphyry	27,0 to 30,0
basalt, diorite, gabbro	27,0 to 31,0
tachylyte	26,0
basaltic lava	24,0
gray wacke, sandstone	21,0 to 27,0
dense limestone	20,0 to 29,0
other limestone	20,0
volcanic tuff	20,0
gneiss	30,0
slate	28,0
NOTE See Section 4.	

Table A.3 - Construction materials-wood

Materials	Density γ [kN/m ³]
wood (see EN 338 for timber strength classes)	
timber strength class C14	3,5
timber strength class C16	3,7
timber strength class C18	3,8
timber strength class C22	4,1
timber strength class C24	4,2
timber strength class C27	4,5
timber strength class C30	4,6
timber strength class C35	4,8
timber strength class C40	5,0
timber strength class D30	6,4
timber strength class D35	6,7
timber strength class D40	7,0
timber strength class D50	7,8
timber strength class D60	8,4
timber strength class D70	10,8
glued laminated timber (see EN 1194 for Timber strength classes)	
homogenous glulam GL24h	3,7
homogenous glulam GL28h	4,0
homogenous glulam GL32h	4,2
homogenous glulam GL36h	4,4
combined glulam GL24c	3,5
combined glulam GL28c	3,7
combined glulam GL32c	4,0
combined glulam GL36c	4,2
plywood	
softwood plywood	5,0
birch plywood	7,0
laminboard and blockboard	4,5
particle boards	
chipboard	7,0 to 8,0
cement-bonded particle board	12,0
flake board, oriented strand board, wafer board	7,0
fibre building board	
hardboard, standard and tempered	10,0
medium density fibreboard	8,0
softboard	4,0
NOTE See Section 4.	

Table A.4 - Construction materials-metals

Materials	Density γ [kN/m ³]
metals	
aluminium	27,0
brass	83,0 to 85,0
bronze	83,0 to 85,0
copper	87,0 to 89,0
iron, cast	71,0 to 72,5
iron, wrought	76,0
lead	112,0 to 114,0
steel	77,0 to 78,5
zinc	71,0 to 72,0

Table A.5 - Construction materials- other materials

Materials	Density γ [kN/m ³]
other materials	
glass, broken	22,0
glass, in sheets	25,0
plastics	
acrylic sheet	12,0
polystyrene, expanded, granules	0,3
foam glass	1,4
AC1 <i>Text deleted</i>	AC1

Table A.6 - Bridge materials

Materials	Density γ [kN/m ³]
<p>pavement of road bridges gussasphalt and asphaltic concrete mastic asphalt hot rolled asphalt</p> <p>infills for bridges sand (dry) ballast, gravel (loose) hardcore crushed slag packed stone rubble puddle clay</p> <p>pavement of rail bridges concrete protective layer normal ballast (e.g. granite, gneiss, etc.) basaltic ballast</p>	<p>24,0 to 25,0 18,0 to 22,0 23,0</p> <p>15,0 to 16,0¹⁾ 15,0 to 16,0¹⁾ 18,5 to 19,5 13,5 to 14,5¹⁾ 20,5 to 21,5 18,5 to 19,5</p> <p>25,0 20,0 26</p>
	<p>Weight per unit bed length^{2) 3)} g_k [kN/m]</p>
<p>structures with ballasted bed 2 rails UIC 60 prestressed concrete sleeper with track fastenings concrete sleepers with metal angle braces timber sleepers with track fastenings</p>	<p>1,2 4,8 - 1,9</p>
<p>structures without ballasted bed 2 rails UIC 60 with track fastenings 2 rails UIC 60 with track fastenings, bridge beam and guard rails</p>	<p>1,7 4,9</p>
<p>¹⁾ Given in other tables as stored materials ²⁾ Excludes an allowance for ballast ³⁾ Assumes a spacing of 600mm</p>	
<p>NOTE 1 The values for track are also applicable outside railway bridges. NOTE 2 See Section 4.</p>	

Table A.7 - Stored materials - building and construction

Materials	Density γ [kN/m ³]	Angle of repose ϕ [°]
aggregates ^(AC1) (see EN 206) _(AC1)		
lightweight	9,0 to 20,0 ¹⁾	30
normal	20,0 to 30,0	30
heavyweight	> 30,0	30
gravel and sand , bulked	15,0 to 20,0	35
sand	14,0 to 19,0	30
blast furnace slag		
lumps	17,0	40
granules	12,0	30
crushed foamed	9,0	35
brick sand , crushed brick, broken bricks	15,0	35
vermiculite		
exfoliated, aggregate for concrete	1,0	-
crude	6,0 to 9,0	-
bentonite		
loose	8,0	40
shaken down	11,0	-
cement		
in bulk	16,0	28
in bag	15,0	-
fly ash	10,0 to 14,0	25
glass , in sheets	25,0	-
gypsum , ground	15,0	25
lignite filter ash	15,0	20
lime	13,0	25
limestone , powder	13,0	25 to 27
magnesite , ground	12,0	-
plastics ,		
polyethylene, polystyrol granulated	6,4	30
polyvinylchloride, powder	5,9	40
polyester resin	11,8	-
glue resins	13,0	-
water , fresh	10,0	
¹⁾ see table A.1 for density classes of lightweight concrete		
NOTE See Section 4.		

Table A.8 - Stored products - agricultural

Products	Density γ [kN/m³]	Angle of repose ϕ [°]
farmyard		
manure (minimum 60 % solids)	7,8	-
manure (with dry straw)	9,3	45
dry chicken manure	6,9	45
slurry (maximum 20 % solids)	10,8	-
fertiliser, artificial		
NPK, granulated	8,0 to 12,0	25
basic slag, crushed	13,7	35
phosphates, granulated	10,0 to 16,0	30
potassium sulphate	12,0 to 16,0	28
urea	7,0 to 8,0	24
fodder, green, loosely stacked	3,5 to 4,5	-
grain		
whole (≤ 14 % moisture content unless indicated otherwise)		
general	7,8	30
barley	7,0	30
brewer's grain (wet)	8,8	-
herbage seeds	3,4	30
maize in bulk	7,4	30
maize in bags	5,0	-
oats	5,0	30
oilseed rape	6,4	25
rye	7,0	30
wheat in bulk	7,8	30
wheat in bags	7,5	-
grass cubes	7,8	40
hay		
(baled)	1,0 to 3,0	-
(rolled bales)	6,0 to 7,0	-
hides and skins	8,0 to 9,0	-
hops	1,0 to 2,0	25
malt	4,0 to 6,0	20
meal		
ground	7,0	45
cubes	7,0	40
peat		
dry, loose, shaken down	1,0	35
dry, compressed in bales	5,0	-
wet	9,5	-
silage	5,0 to 10,0	-
straw		
in bulk (dry)	0,7	-
baled	1,5	-
tobacco in bales	3,5 to 5,0	-
wool		
in bulk	3,0	-
baled	7,0 to 13,0	-

NOTE See Section 4.

AC1 Table A.9 - Stored products - foodstuffs

Products	Density γ [kN/m ³]	Angle of repose ϕ [°]
eggs , in stands	4,0 to 5,0	-
flour		
bulk	6,0	25
bagged	5,0	-
fruit		
apples		
- loose	8,3	30
- boxed	6,5	-
cherries	7,8	-
pears	5,9	-
raspberries, in trays	2,0	-
strawberries, in trays	1,2	-
tomatoes	6,8	-
sugar		
loose, piled	7,5 to 10,0	35
dense and bagged	16,0	-
vegetables, green		
cabbages	4,0	-
lettuce	5,0	-
vegetables, legumes		
beans		35
- general	8,1	30
- soya	7,4	-
peas	7,8	-
vegetables, root		
general	8,8	-
beetroot	7,4	40
carrots	7,8	35
onions	7	35
turnips	7	35
potatoes		
in bulk	7,6	35
in boxes	4,4	-
sugarbeet,		
dried and chopped	2,9	35
raw	7,6	-
wet shreds	10,0	-

NOTE See Section 4.

AC1

Table A.10 - Stored products - liquids

Products	Density γ [kN/m ³]
beverages	
beer	10,0
milk	10,0
water, fresh	10,0
wine	10,0
natural oils	
castor oil	9,3
glycerol (glycerine)	12,3
linseed oil	9,2
olive oil	8,8
organic liquids and acids	
alcohol	7,8
ether	7,4
hydrochloric acid (40 % by weight)	11,8
methylated spirit	7,8
nitric acid (91 % by weight)	14,7
sulphuric acid (30 % by weight)	13,7
sulphuric acid (87 % by weight)	17,7
turpentine, white spirit	8,3
hydrocarbons	
aniline	9,8
benzene (benzol)	8,8
coal tar	10,8 to 12,8
creosote	10,8
naphtha	7,8
paraffin (kerosene)	8,3
benzine (benzoline)	6,9
oil, crude (petroleum)	9,8 to 12,8
diesel	8,3
fuel	7,8 to 9,8
heavy	12,3
lubricating	8,8
petrol (gasolene, gasoline)	7,4
liquid gas	
butane	5,7
propane	5,0
other liquids	
mercury	133
red lead paint	59
white lead, in oil	38
sludge, over 50 % by volume water	10,8
NOTE See Section 4.	

Table A.11 - Stored products - solid fuels

Products	Density γ [kN/m ³]	Angle of repose ϕ [°]
charcoal		
air-filled	4	-
air-free	15	-
coal		
block briquettes, tipped	8	35
block briquettes, stacked	13	-
egg briquettes	8,3	30
coal, raw from pit	10	35
coal in washing pools	12	-
coal dust	7	25
coke	4,0 to 6,5	35 to 45
middlings in the quarry	12,3	35
waste washing tips in colliery	13,7	35
all other kinds of coal	8,3	30 to 35
firewood	5,4	45
lignite/brown coal		
briquettes, tipped	7,8	30
briquettes, stacked	12,8	-
damp	9,8	30 to 40
dry	7,8	35
dust	4,9	25 to 40
low-temperature coke	9,8	40
peat		
black, dried, firmly packed	6 to 9	-
black, dried, loosely tipped	3 to 6	45
NOTE See Section 4.		

Table A.12 - Stored products - industrial and general

Products	Density γ [kN/m ³]	Angle of repose ϕ [°]
books and documents		
books and documents, densely stored	6,0 8,5	- - -
filing racks and cabinets	6,0	-
garments and rags, bundled	11,0	-
ice, lumps	8,5	-
leather, piled	10,0	-
paper		
in rolls	15,0	-
piled	11,0	-
rubber	10,0 to 17,0	-
rock salt	22,0	45
salt	12,0	40
sawdust		
dry, bagged	3,0	-
dry, loose	2,5	45
wet, loose	5,0	45
tar, bitumen	14,0	-
NOTE See Section 4.		

ANNEX B
(informative)
Vehicle barriers and parapets for car parks

B(1) Barriers and parapets in car parking areas should be designed to resist the horizontal loads given in B(2).

B(2) The horizontal characteristic force F (in kN), normal to and uniformly distributed over any length of 1,5 m of a barrier for a car park, required to withstand the impact of a vehicle is given by:

$$F = 0,5mv^2 / (\delta_c + \delta_b)$$

Where :

- m is the gross mass of the vehicle in (kg)
- v is the velocity of the vehicle (in m/s) normal to the barrier
- δ_c is the deformations of the vehicle (in mm)
- δ_b is the deformations of the barrier (in mm)

B(3) Where the car park has been designed on the basis that the gross mass of the vehicles using it will not exceed 2500 kg the following values are used to determine the force F :

$$m = 1500 \text{ kg}$$

$$v = 4,5 \text{ m/s}$$

$$\delta_c = 100 \text{ mm unless better evidence is available.}$$

For a rigid barrier, for which δ_b may be given as zero, the characteristic force F appropriate to vehicles up to 2500 kg gross mass is taken as 150 kN.

B(4) Where the car park has been designed for vehicles whose gross mass exceeds 2500 kg the following values are used to determine the characteristic force F .

$$m = \text{the actual mass of the vehicle for which the car park is designed (in kg)}$$

$$v = 4,5 \text{ m/s}$$

$$\delta_c = 100 \text{ mm unless better evidence is available}$$

B(5) The force determined as in B (3) or B (4) may be considered to act at bumper height. In the case of car parks intended for vehicles whose gross mass does not exceed 2500 kg this height may be taken as 375 mm above the floor level.

B(6) Barriers to access ramps of car parks have to withstand one half of the force determined in B (3) or B (4) acting at a height of 610 mm above the ramp.

B(7) Opposite the ends of straight ramps intended for downward travel which exceed 20 m in length the barrier has to withstand twice the force determined in B (3) acting at a height of 610 mm above the ramp.

Bibliography

ISO 2394 General principles on reliability for structures

ISO 3898 Basis of design of structures - Notations. General symbols

ISO 8930 General principles on reliability for structures. List of equivalent terms

